

Bluetooth Speed Sensor | Quick Start

Box Content

ITEM	Quantity
BLE Speed Sensor (Grey)	1
Cover (Black)	1
O-ring (Assembled within Cover)	1
M2.5x5 Screw	4
M2.5 Allen Key	1
Magnetic Pin (dia.: 3 mm)	1



Fig. 1: Assembled Sensor

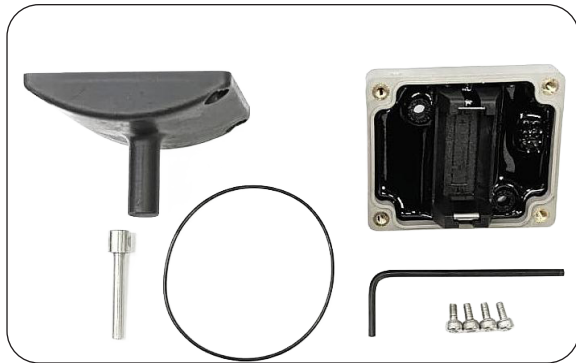

Fig. 2: Box Content

Start with the Sensor:

1. Use only **CR2 3V battery**
2. Insert the battery into the battery seat
3. Close with black cover
4. Tighten the 4 Allen M2.5 screws

How to clamp and use the Sensor:

1. Insert the Magnetic Pin into the JET Spindle like a normal cutting tool
2. Use a DIAL INDICATOR clamp
3. Insert the long shank of the Speed Sensor into the clamp and tighten it
4. Place the sensor 2mm away from the Magnetic Pin

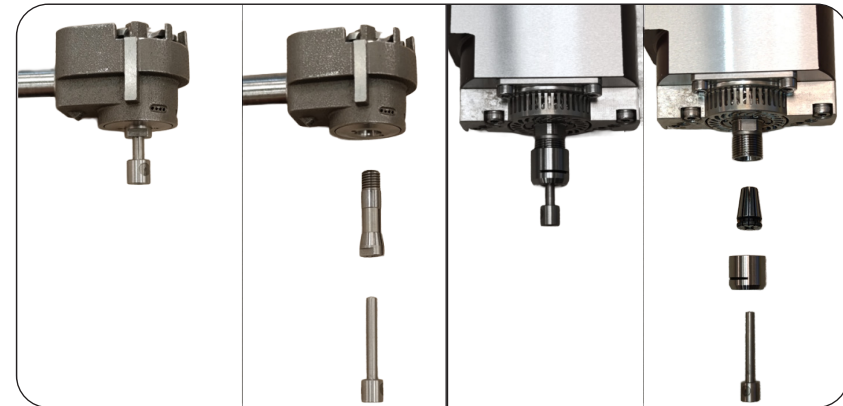

Fig. 3: Insert Magnetic Pin into the JET Spindle (l.: MICRO JET, r.: SWISS JET)

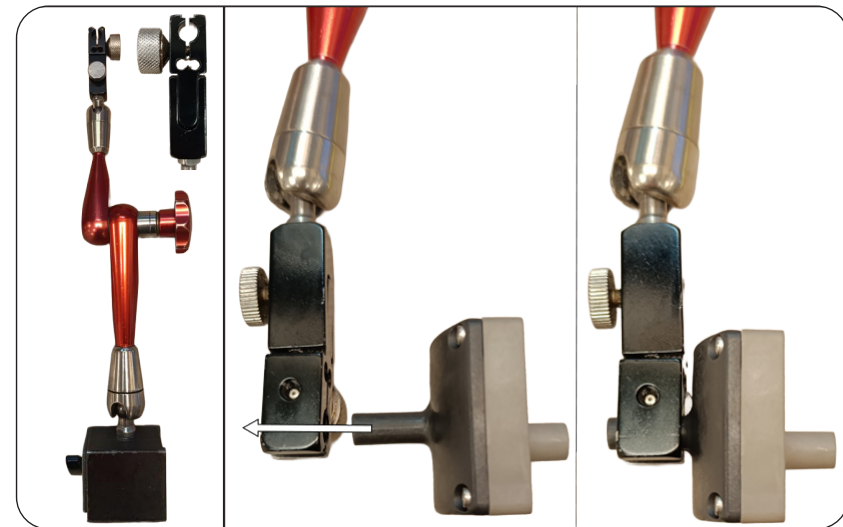

Fig. 4: Insert Speed Sensor into clamp

Bluetooth Speed Sensor | Quick Start

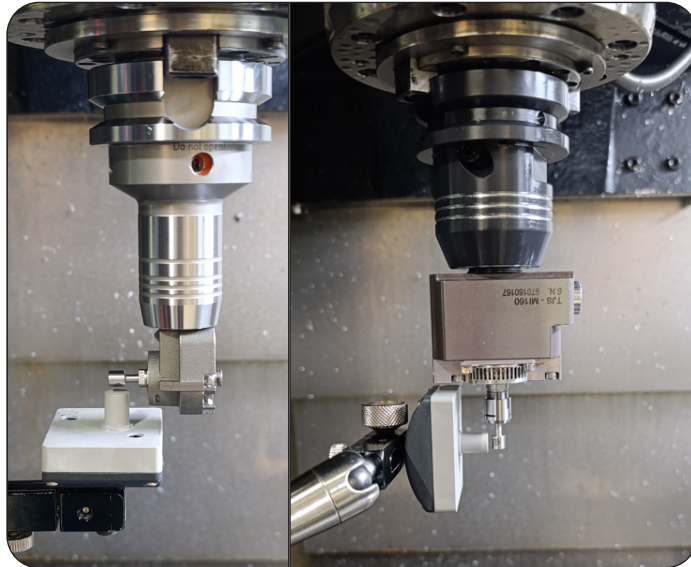

Fig. 5: Sensor in real life use (L.: MICRO JET, r.: SWISS JET)

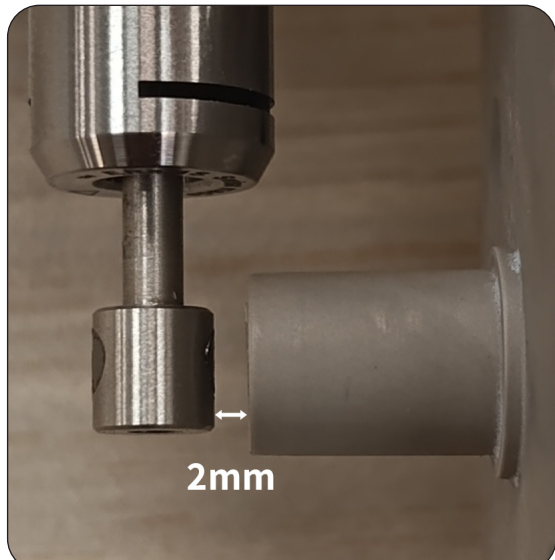

Fig. 6: 2mm Distance from Magnetic Pin to Speed Sensor

Download the Jet Spindle Monitor App:

iPhone & iPad IOS

Requires iPhone 10 or newer. Search "Jet Spindle Monitor" on your device or just scan the QR code.

Download on the
App Store



Android Phone & Device Google

Requires Android 10 or newer. Search "Jet Spindle Monitor" on your device or just scan the QR code.

GET IT ON
Google Play



How to use the Jet Spindle Monitor App:

1. Open the Jet Spindle Monitor App
2. Tap on the corresponding Spindle to see a detailed overview
3. Turn on the machines high-pressure coolant pump
4. RPM speed will be displayed in the Jet Spindle Monitor App automatically
5. Adjust cutting conditions, based on the resulting speed

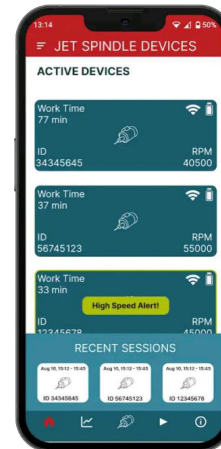

Tap on a Jet Spindle to see a detailed overview



Detailed Jet Information

Detailed 2 Minutes View

Full View