

The information disclosed in this document is proprietary to Colibri Spindles Ltd. and may not be used for manufacture or any other purpose without the written consent of Colibri Spindles Ltd.

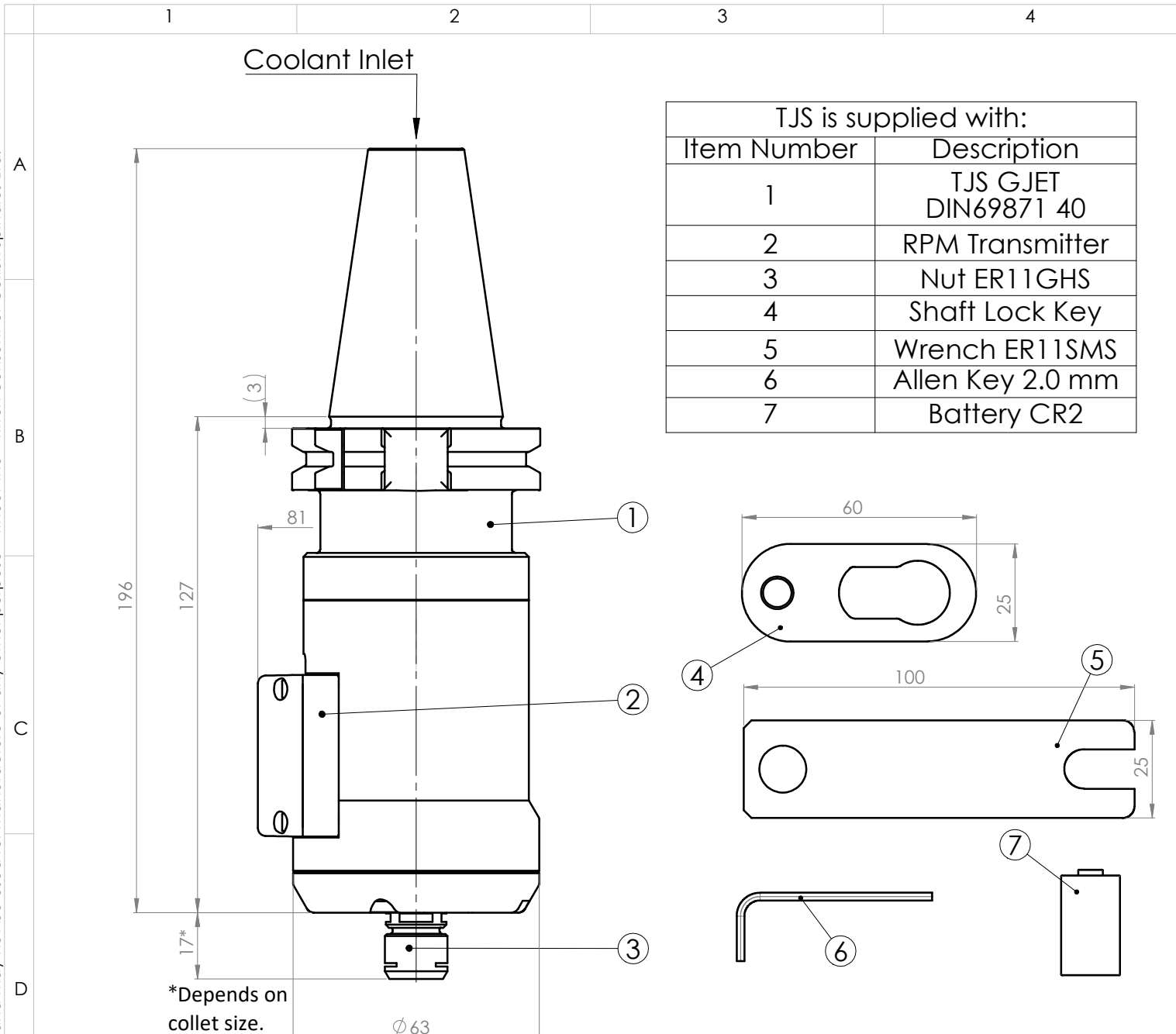

TJS is supplied with:	
Item Number	Description
1	TJS GJET DIN69871 40
2	RPM Transmitter
3	Nut ER11GHS
4	Shaft Lock Key
5	Wrench ER11SMS
6	Allen Key 2.0 mm
7	Battery CR2

*Depends on collet size.

Coolant inlet pressure [bar]*	20-40
Rotation speed [Krpm]**	35-55
Flow rate [l/min]	10-20
Maximum tool shank diameter [mm]	7.0
Maximum tool diameter [mm]	3.5
System weight [kg]	2.1

* Coolant pressure is measured at the spindle inlet
 ** Spindle speed may vary up to 7%

Surface roughness: ✓	Dimensions are in: mm	Projection style:
Unspecified tolerances ±0.1; ±0°30' Break all sharp edges R0.2 max or 0.2x45° chamfer		

Operation Name:	Customer Drawing
Project:	TJS Green JET

Part Name:	TJS GJET DIN69871 40		
Part No:	37-035-849	Rev:	00

Material:	
Per:	
Hardness:	
Coating:	
Per:	

CONFIDENTIAL		Name	Date	Signature	Sheet
Design					1 of 1
Drawn	T.L.	23/01/19			
Checked					Scale: Size:
Approved	S.W.	23/01/19			A4
Weight:	gr ref				